



Used to manipulate round components, these grippers guarantee a high precision thanks to the synchronizes closure of the three gripping jaws and to the prismatic guides system. Ideal for specific sectors like pick-and-place (P&Ps), machines tools interlocking and many other fields, grippers of PX series cover all different exigencies of modern industrial automation, thanks to their compact dimensions.

Utilisées pour la manipulation des composants ronds, ces pinces peuvent garantir une grande précision grâce au mouvement synchronisé des mâchoires et au système de guidage prismatique. Idéales pour des secteurs spécifiques comme pick-and-place (P&Ps), machines-outils emboîtables et beaucoup d'autre utilisations, les pinces de la série PX couvrent toutes les exigences différentes de l'automatisation industrielle moderne, grâce à leur dimension compacte.

Utilizzate per la manipolazione di pezzi tondi, queste pinze garantiscono un grande precisione grazie alla chiusura sincronizzata delle tre dita di presa e al sistema prismatico delle guide. Ideale per settori come pick-and-place (P&Ps), asservimento macchine utensili e tanti altri settori, le pinze della serie PX rispondono a tutte le esigenze dell'automazione industriale moderna, grazie all'estrema compattezza degli ingombri.

ORDERING CODE / CODIFICATION / CHIAVE DI CODIFICA

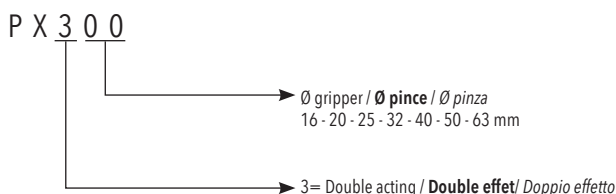

TECHNICAL DATA / DONNÉES TECHNIQUES / DATI TECNICI

Ø	External gripping force (5 bar) Force de prise externe (bar) Forza di presa esterna (5bar)	Internal gripping force (5 bar) Force de prise interne (bar) Forza di presa interna (5bar)	Weight Poids Peso
Ø16	14 (N)	16 (N)	80 gr
Ø20	25 (N)	28 (N)	110 gr
Ø25	42 (N)	47 (N)	140 gr
Ø32	74 (N)	82 (N)	237 gr
Ø40	118 (N)	130 (N)	351 gr
Ø50	187 (N)	204 (N)	541 gr
Ø63	335 (N)	359 (N)	1020 gr

Fluid / Fluide / Fluido	Lubricated or non lubricated air / Air lubrifié ou non lubrifié / Aria con o senza lubrificazione
Operating temperature range / Température d'utilisation / Temp. di esercizio	-10°C / +60°C
Pressure range / Pression d'utilisation / Pressione di utilizzo	2 - 7 bar
Action tolerance / Tolérance d'action / Tolleranza d'azione	± 0.01 mm
Max operating frequency / Fréquence de fonctionnement max. / Max frequenza operativa	Ø16-Ø20-Ø25=120 c.p.m. / Ø32-Ø40 Ø50 Ø63=60 c.p.m

COMPONENTS / COMPOSANTS / COMPONENTI

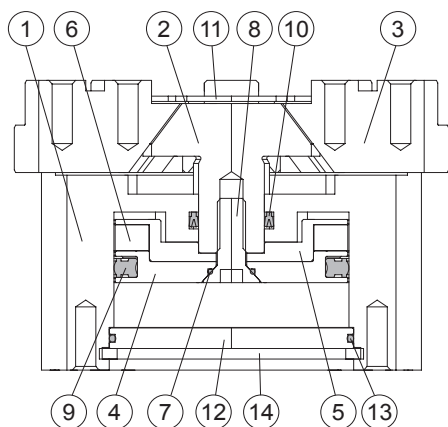

N.	DESCRIPTION / DESCRIPTION / DESCRIZIONE	MATERIAL / MATIÈRE / MATERIALE
1	body / corp / corpo	aluminium / aluminium / alluminio
2	lever / levier / leva	steel / acier / acciaio
3	guide / guidage / guida	steel / acier / acciaio
4	piston / piston / pistone	aluminium / aluminium / alluminio
5	piston / piston / pistone	aluminium / aluminium / alluminio
6	magnet / aimant / magnete	magnetic material / matériau magn. / materiale mag.
7	O-ring	NBR
8	screw / vis / vite	steel / acier / acciaio
9	seal / joint / guarnizione	NBR
10	seal / joint / guarnizione	NBR
11	cover / couverture / coperchio	stainless steel / acier inox / acciaio inox
12	rear cap / fond arrière / testata post	aluminium / aluminium / alluminio
13	O-ring	NBR
14	snap ring / siège / seeger	steel / acier / acciaio

EXTERNAL GRIPPING FORCE / FORCE DE PRÉHENSION EXTERNE / FORZA DI PRESA ESTERNA

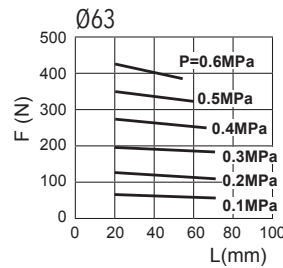
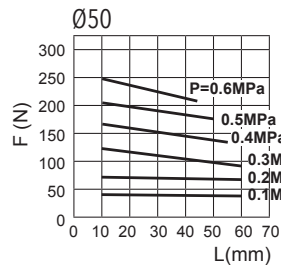
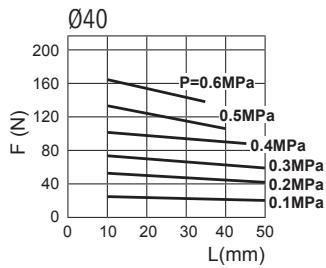
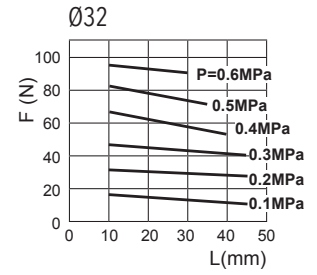
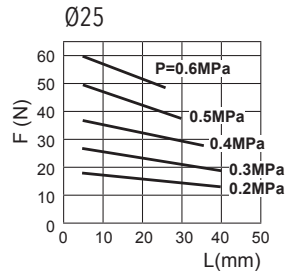
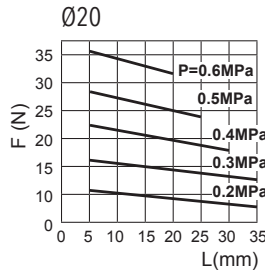
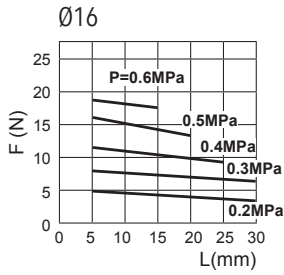
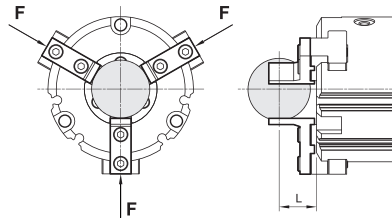

INTERNAL GRIPPING FORCE / FORCE DE PRÉHENSION INTERNE / FORZA DI PRESA INTERNA

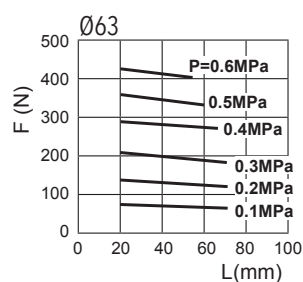
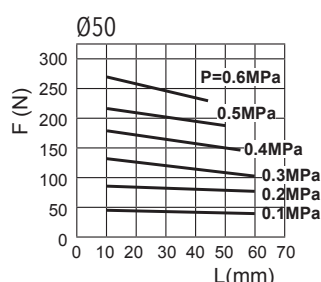
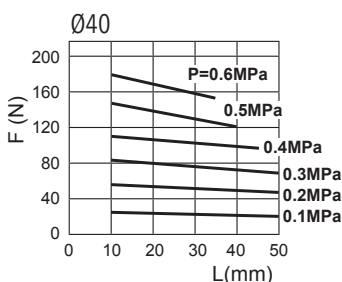
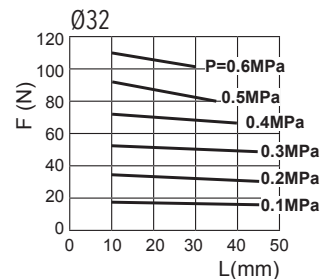
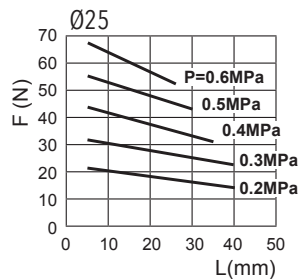
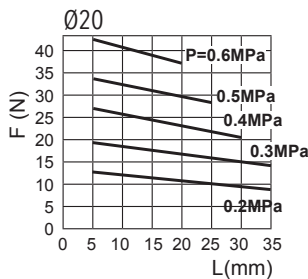
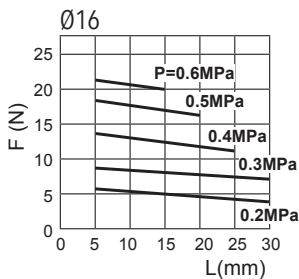
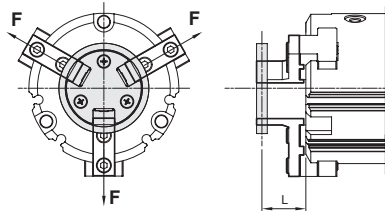

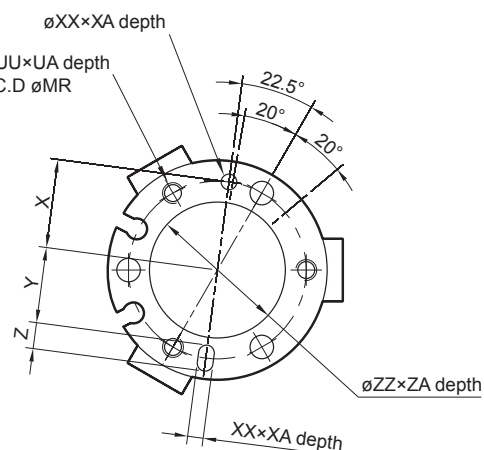
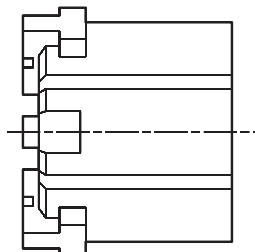
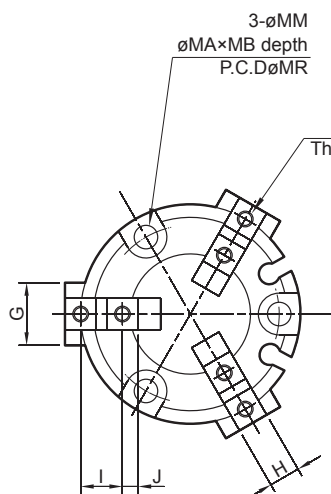
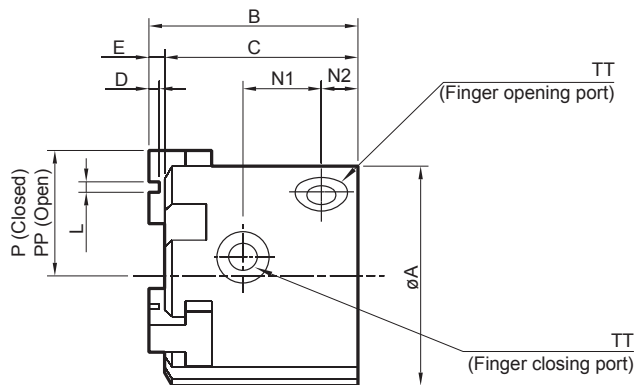

Ø	A	B	C	D	E	G	H	I	J	L	MA	MB	MM	MR	N1	N2	P	PP	QA	QQ	TT	UA
16	30	35	32	2 ^{+0.2} ₀	3	8	5 ^{-0.01} _{-0.03}	6	2	2 ^{+0.04} _{+0.01}	6	6	3.4	25	10	7	5	7	5	M3x0.5	M3x0.5	6
20	36	39	36	2 ^{+0.2} ₀	3	10	6 ^{-0.01} _{-0.03}	7	2.5	2 ^{+0.04} _{+0.01}	6	6	3.4	29	13	7	6	8	5	M3x0.5	M5x0.8	6
25	42	41	38	2 ^{+0.2} ₀	3	12	6 ^{-0.01} _{-0.03}	8	3	2 ^{+0.04} _{+0.01}	8	9	4.5	34	14.5	7.5	7	10	5	M3x0.5	M5x0.8	8
32	52	45	42	2 ^{+0.2} ₀	3	14	8 ^{-0.01} _{-0.03}	11	4.5	2 ^{+0.04} _{+0.01}	8	9	4.5	44	16	8.5	8	12	8	M4x0.7	M5x0.8	8
40	62	49	46	2 ^{+0.2} ₀	3	16	8 ^{-0.01} _{-0.03}	12	4.5	3 ^{+0.04} _{+0.01}	9.5	9	5.5	53	17.5	9.5	10	14	8	M4x0.7	M5x0.8	10
50	70	57	54	2 ^{+0.2} ₀	3	18	10 ^{-0.01} _{-0.03}	14	5	4 ^{+0.04} _{+0.01}	9.5	12	5.5	62	21	9.5	11	17	9	M5x0.8	M5x0.8	10
63	86	68	64	3 ^{+0.2} ₀	4	24	12 ^{-0.01} _{-0.03}	17	5.5	6 ^{+0.04} _{+0.01}	11	14	6.6	76	24	12	15	23	9	M5x0.8	M5x0.8	12

Ø	UU	X	XA	XX	Y	Z	ZA	ZZ
16	M3x0.5	12.5	2	2 ^{+0.04} _{+0.01}	11	3	1.5	17 ^{+0.05} ₀
20	M3x0.5	14.5	2	2 ^{+0.04} _{+0.01}	13	3	1.5	21 ^{+0.05} ₀
25	M4x0.7	17	3	3 ^{+0.04} _{+0.01}	14.5	5	1.5	26 ^{+0.05} ₀
32	M4x0.7	22	3	3 ^{+0.04} _{+0.01}	19.5	5	2	34 ^{+0.05} ₀
40	M5x0.8	26.5	4	4 ^{+0.04} _{+0.01}	23.5	6	2	42 ^{+0.05} ₀
50	M5x0.8	31	4	4 ^{+0.04} _{+0.01}	28	6	2	52 ^{+0.05} ₀
63	M6x1.0	38	5	5 ^{+0.04} _{+0.01}	34.5	7	2.5	65 ^{+0.05} ₀

ROUND SWITCH
CAPTEUR ROND
 SENSORE TONDO

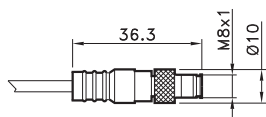
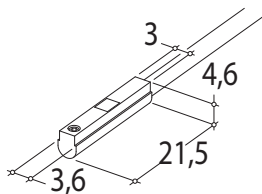

4= black / **noire** / nero
 1= brown / **brun** / marrone
 3= blue / **bleu** / azzurro

CODE

AR4018010	REED (MT.2,5) / REED (MT.2,5) / REED (MT.2,5)
AR4018020	HALL (MT.2,5) / HALL (MT.2,5) / HALL (MT.2,5)
AR4018110	REED + M8 (CM 30) / REED + M8 / REED + M8 (CM 30)
AR4018120	HALL + M8 (CM 30) / HALL + M8 / HALL + M8 (CM 30)

For technical data see page 1.75

Pour les données techniques, voir page 1.75

Per i dati tecnici vedere pag. 1.75